

LeDisplayCase
See in a different light

Custom Engraving Assembly Instructions

 ledisplaycase.com

 [ledisplaycase](https://facebook.com/ledisplaycase)

 sales@ledisplaycase.com

 [ledisplaycase](https://instagram.com/ledisplaycase)

Parts List

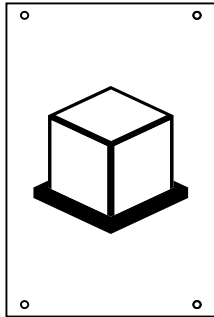

Custom Engraved Panel: 1 pc

Fits directly onto your display case
by replacing one existing panel

3.97" X 3.97" X 5.90" (10cm X 10cm X 15cm)
7.87" X 7.87" X 11.81" (20cm X 20cm X 30cm)
11.81" X 11.81" X 17.72" (30cm X 30cm X 45cm)

Step 1 : Assembly with Display Case

Complete the assembly of your display case step 3.1/3.2 of "Display Case Assembly Instructions" before proceeding.

If you have the Display Case with the LED Base, remove the Display Case from the Base by lifting it up before proceeding

Instructions can be found at:
ledisplaycase.com/manuals

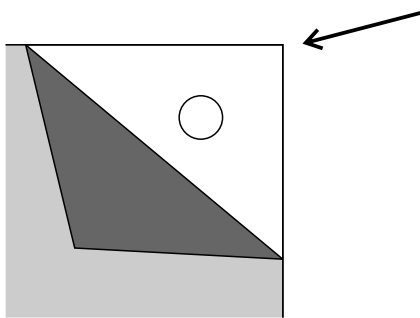

Each acrylic panel has a protective plastic/paper sheet on both sides to prevent damage.

Partially peel off the corners of the protective plastic on both sides sufficiently to allow the installation of the bracket and rivets.

Start removing from the corners.

Step 1 : Assembly with Display Case Cont.

<u>Display Case Size</u>	<u>Page Number</u>
3.97in X 3.97 in X 5.90in 10cm X 10cm X 15cm	Proceed to step 2.1 (Pg. 5)
7.87in X 7.87in X 11.81in 20cm X 20cm X 30cm	Proceed to step 2.1 (Pg. 5)
11.81in X 11.81in X 17.72in 30cm X 30cm X 45cm	Proceed to step 2.2 (Pg. 7)

Step 2.1: Disassembly of Display Case

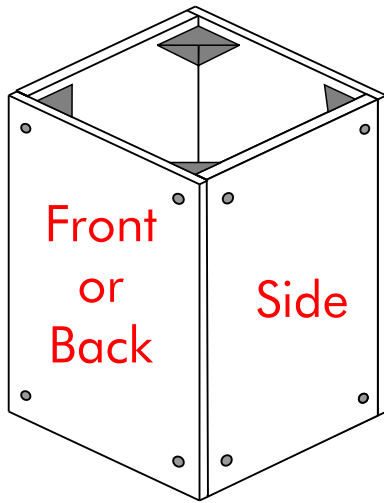

Rotate the Display Case with the opening facing upwards as shown.

The Custom Engraved sheet can replace either the front or back panel of the Display Case. We recommend replacing the back panel.

*Note that the front/back panel is larger than the side panels.

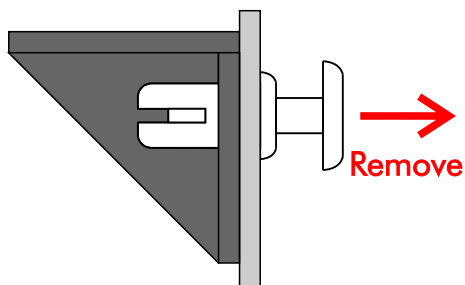
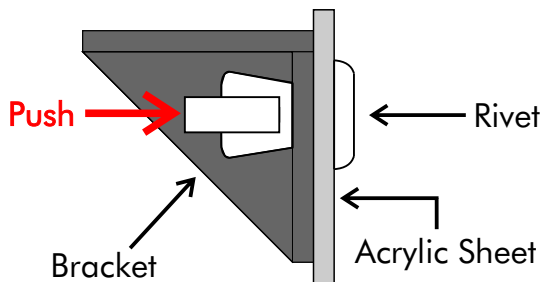

Remove the 4 rivets securing the front/back panel by pushing the centre of the rivets from the inside. Once completed, the front/back panel can be removed.

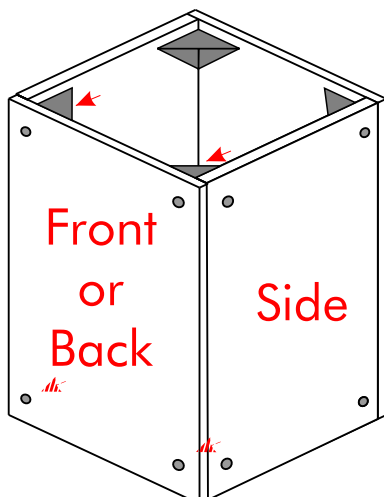

Step 3.1: Re-assembly of Display Case with Custom Engraved panel

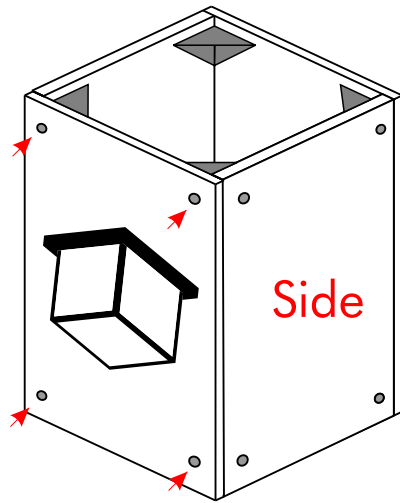

Replace the front/back panel that you removed with the Custom Engraved panel before re-installing the 4 rivets.

Ensure the orientation of the Custom Engraved panel follows the orientation of the case.

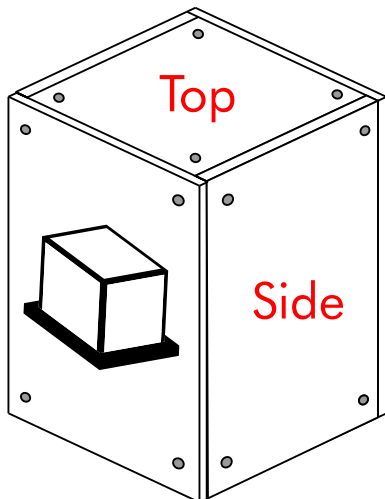

Remove the remaining protective plastic/paper sheet on the panel before rotating the case back to its correct orientation.

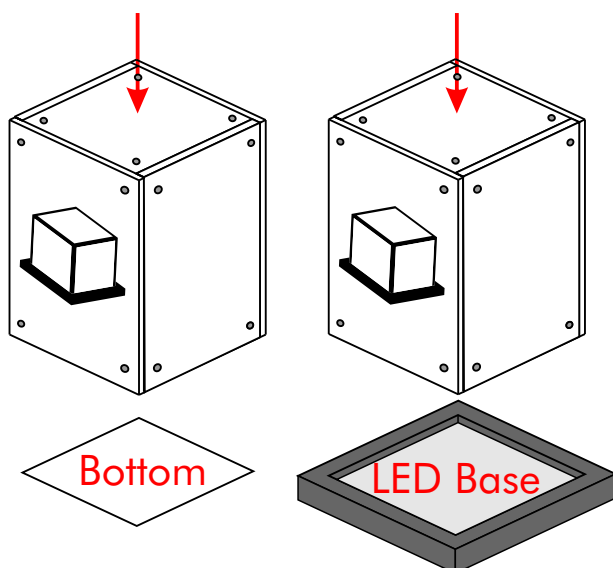

Place your figurine on the bottom panel/LED Base before placing the case over the figurine, ensuring that the case sits snugly with the bottom panel/LED Base.

Step 2.2: Disassembly of Display Case

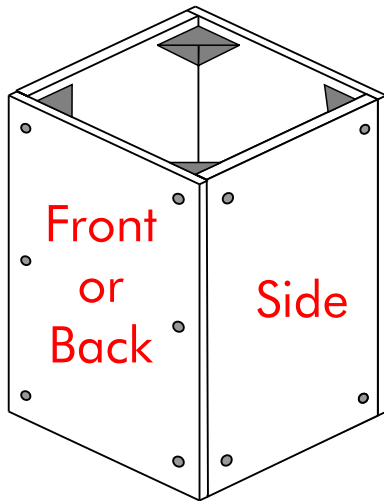

Rotate the Display Case with the opening facing upwards as shown.

The Custom Engraved sheet can replace either the front or back panel of the Display Case. We recommend replacing the back panel.

*Note that the front/back panel is larger than the side panels.

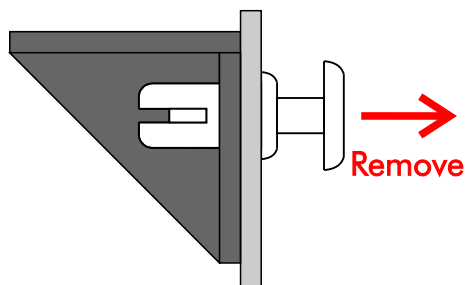
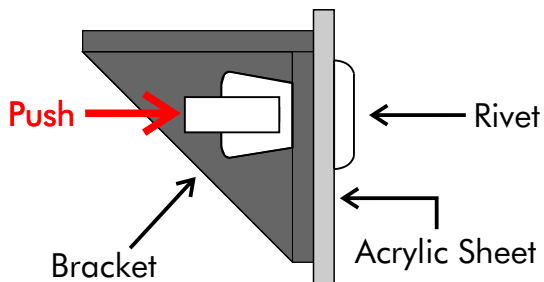

Remove the 6 rivets securing the front/back panel by pushing the centre of the rivets from the inside. Once completed, the front/back panel can be removed.

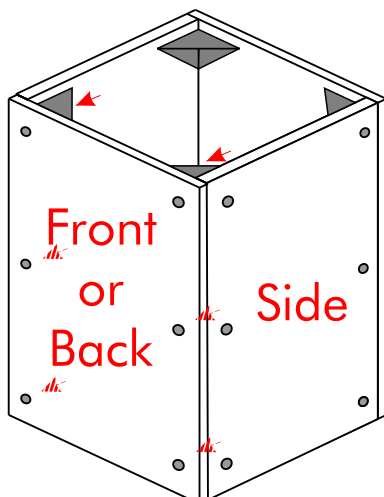

Step 3.2: Re-assembly of Display Case with Custom Engraved panel

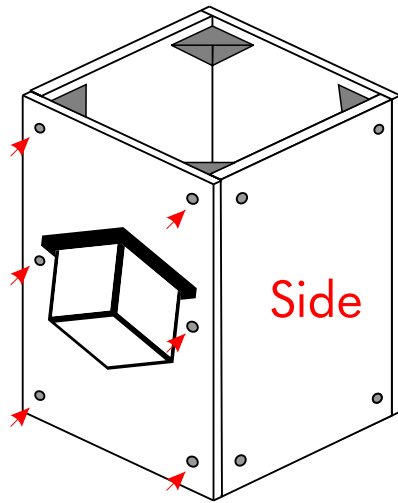

Replace the front/back panel that you removed with the Custom Engraved panel before re-installing the 6 rivets.

Ensure the orientation of the Custom Engraved panel follows the orientation of the case.

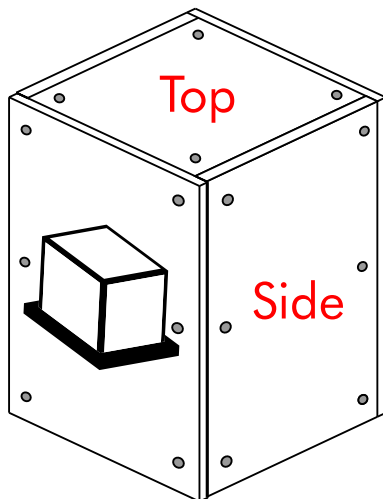

Remove the remaining protective plastic/paper sheet on the panel before rotating the case back to its correct orientation.

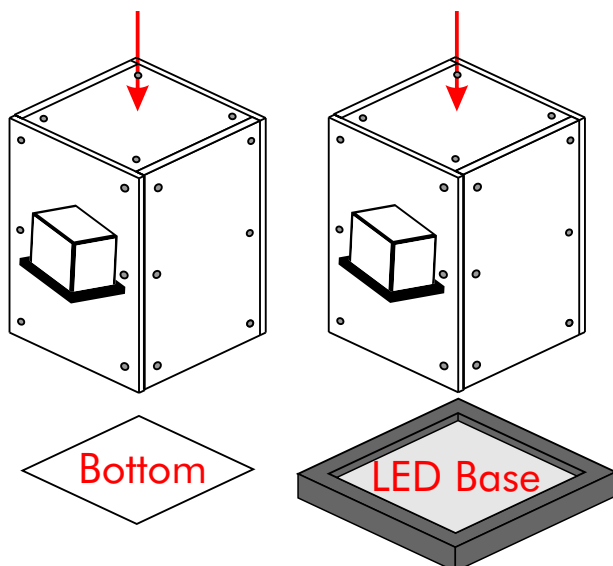

Place your figurine on the bottom panel/LED Base before placing the case over the figurine, ensuring that the case sits snugly with the bottom panel/LED Base.

Admire your Display Case

Your custom engraved display case is now complete. Take some time to admire the design that you have chosen

If you haven't done so, we recommend our LED base to make your figure a statement piece.

Find out more at
ledisplaycase.com