

**LeDisplayCase**  
See in a different light

# Display Case Assembly Instructions

 [ledisplaycase.com](https://ledisplaycase.com)

 [ledisplaycase](https://facebook.com/ledisplaycase)

 [sales@ledisplaycase.com](mailto:sales@ledisplaycase.com)

 [ledisplaycase](https://instagram.com/ledisplaycase)

# Parts List

3.97in X 3.97 in X 5.90in  
10cm X 10cm X 15cm

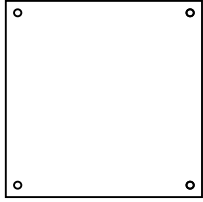

Top/Bottom Panel: 2 pcs  
3.70" X 3.70" (94mm X 94mm)



Front/Back Panel: 2 pcs  
3.93" X 5.91" (100mm X 150mm)

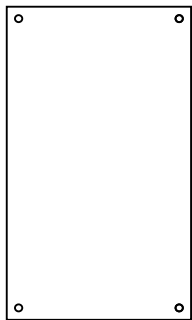

Side Panel: 2 pcs  
3.70" X 5.91" (94mm X 150mm)  
**\*Side Panels are smaller  
than Front/Back Sheets**

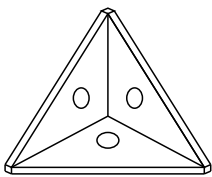

Brackets: 8 pcs

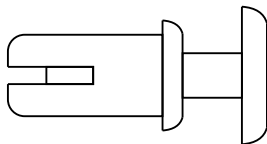

Rivets: 24 pcs  
**\*Do not push in rivet till step 2\***

# Parts List

7.87in X 7.87in X 11.81in  
20cm X 20cm X 30cm

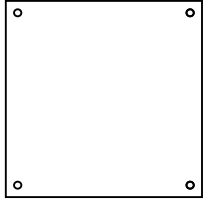

Top/Bottom Panel: 2 pcs  
7.64" X 7.64" (194mm X 194mm)



Front/Back Panel: 2 pcs  
7.87" X 11.81" (200mm X 300mm)

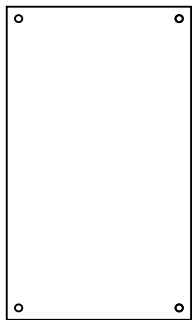

Side Panel: 2 pcs  
7.64" X 11.81" (194mm X 300mm)

**\*Side Panels are smaller  
than Front/Back Sheets**

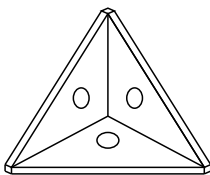

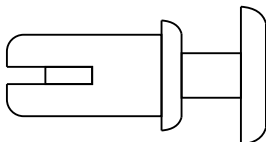

Brackets: 8 pcs



Rivets: 24 pcs  
**\*Do not push in rivet till step 2\***

# Parts List

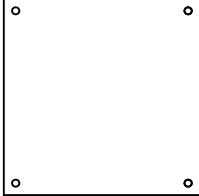
11.81in X 11.81in X 17.72in  
30cm X 30cm X 45cm

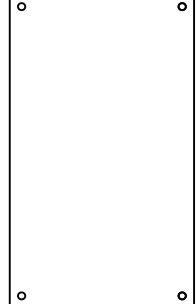
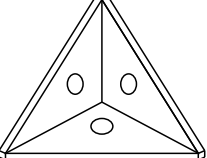
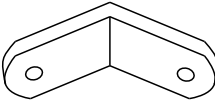
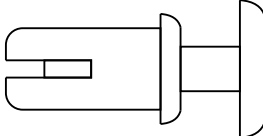
	<p>Top/Bottom Panel: 2 pcs 11.57" X 11.57" (294mm X 294mm)</p>
	<p>Front/Back Panel: 2 pcs 11.81" X 17.72" (300mm X 450mm)</p>
	<p>Side Panel: 2 pcs 11.81" X 17.72" (300mm X 450mm) <b>*Side Panels are smaller than Front/Back Sheets</b></p>
	<p>Brackets: 8 pcs</p>
	<p>Side Brackets: 4 pcs</p>
	<p>Rivets: 32 pcs <b>*Do not push in rivet till step 2*</b></p>

## Step 1: Partial removal of protective panel

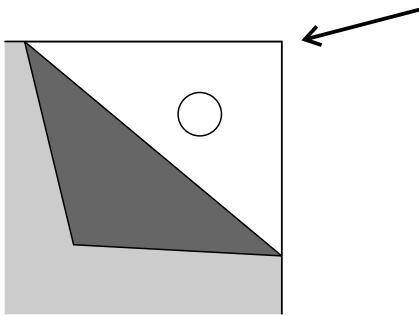

Each acrylic panel has a protective plastic/paper sheet on both sides to prevent damage.

Partially peel off the corners of the protective plastic on both sides sufficiently to allow the installation of the bracket and rivets.

Start removing from the corners.

## Step 2: Attach brackets on **Top** panel

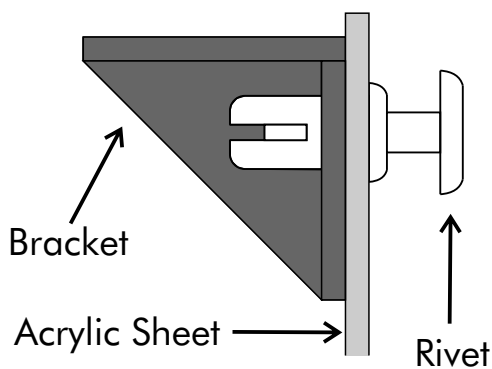

Align the holes in the bracket with the holes in the **top** acrylic panel.

Pierce the rivet through both the bracket and acrylic panel.

*\*Note\** Rivets should be inserted from the outside of the case

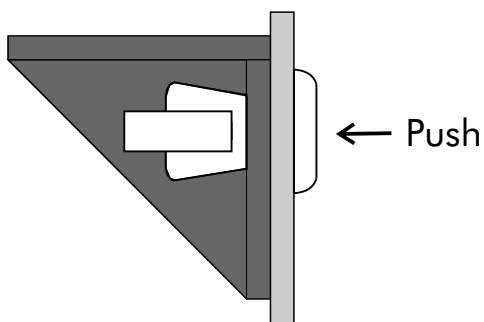

Push the head of the rivet as far as it will go. It should completely rest against the acrylic.

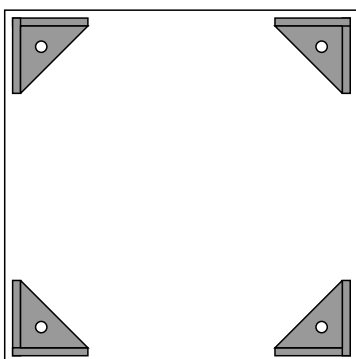

Repeat the process 4 times on each of the 4 holes on the top sheet.

### Step 3: Attach surrounding panels to brackets

<u>Display Case Size</u>	<u>Page Number</u>
3.97in X 3.97 in X 5.90in 10cm X 10cm X 15cm	Proceed to step 3.1 (Pg. 7)
7.87in X 7.87in X 11.81in 20cm X 20cm X 30cm	Proceed to step 3.1 (Pg. 7)
11.81in X 11.81in X 17.72in 30cm X 30cm X 45cm	Proceed to step 3.2 (Pg. 9)

## Step 3.1: Attach surrounding panels to brackets

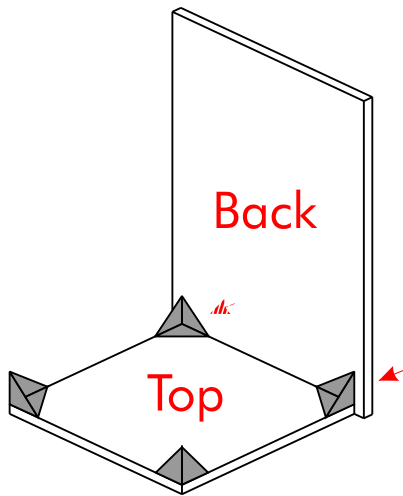

Install the back panel using the rivets with the same method as in step 2. The back sheet is slightly bigger than the side panels.

\*Rivet directions indicated by the red arrow

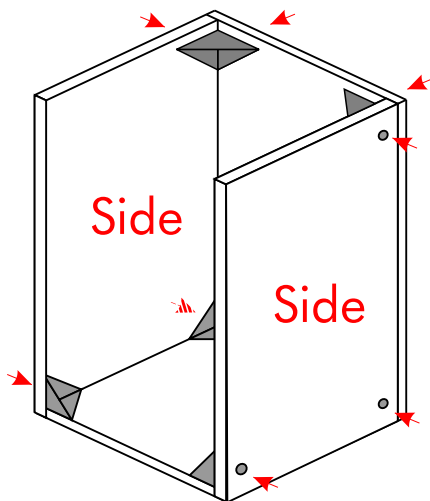

Install the side panels using the rivets with the same method as in step 2.

\*Rivet directions indicated by the red arrow

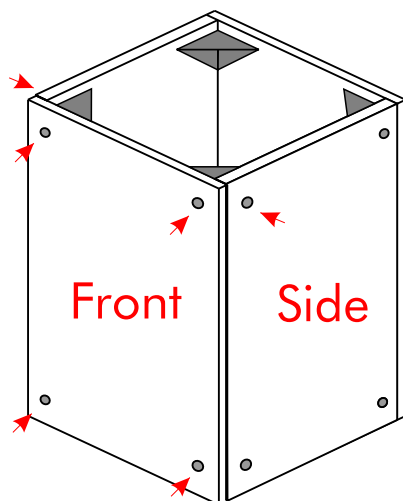

Install the front panel using the rivets with the same method as in step 2.

\*Rivet directions indicated by the red arrow

## Step 4.1: Final Assembly

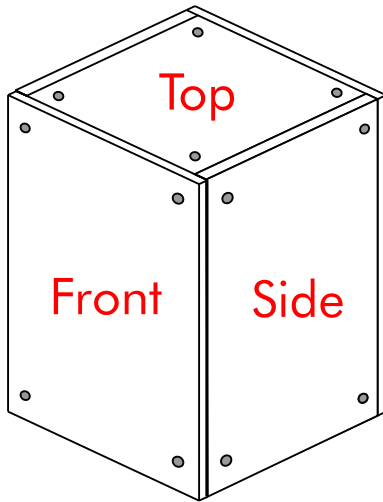

Remove the remaining protective plastic/paper sheet on every panel before rotating the display case back to it's correct orientation.

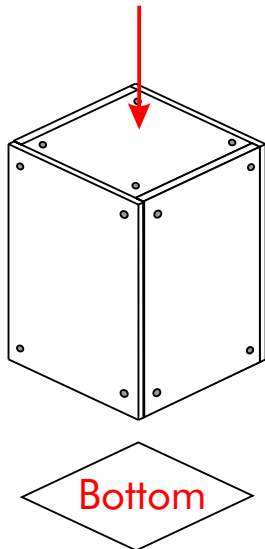

Place your figurine on the bottom panel before placing the case over the figurine, ensuring that the case sits snugly with the bottom panel.

Installation of the bottom 4 rivets is optional and not necessary.

Installing the bottom 4 rivets will make the case more sturdy but more difficult to access.

Continue to Pg. 11



## Step 3.2: Attach surrounding panels to brackets

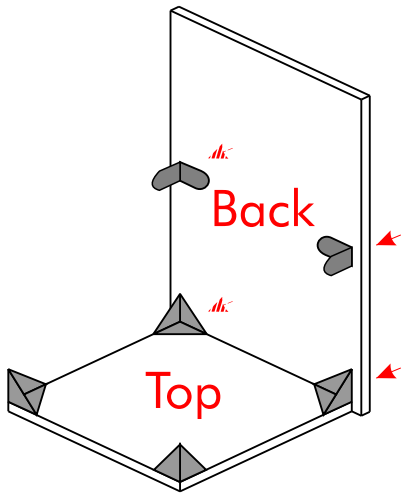

Install the back panel using the rivets with the same method as in step 2. The back sheet is slightly bigger than the side panels.

\*Rivet directions indicated by the red arrow

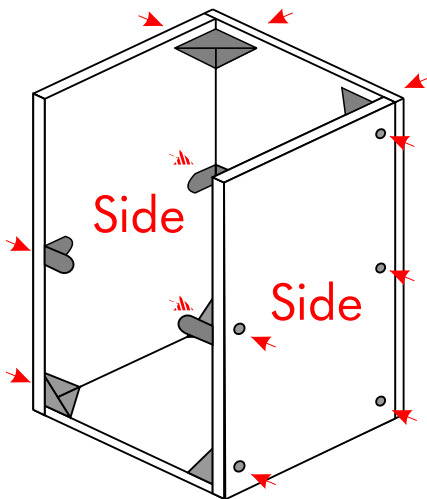

Install the side panels using the rivets with the same method as in step 2.

\*Rivet directions indicated by the red arrow

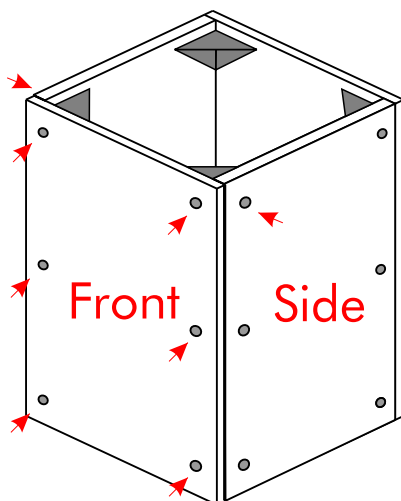

Install the front panel using the rivets with the same method as in step 2.

\*Rivet directions indicated by the red arrow

## Step 4.2: Final Assembly

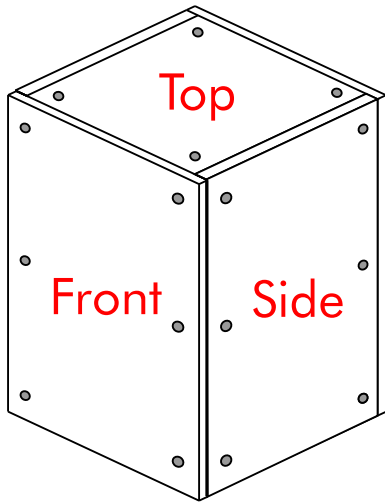

Remove the remaining protective plastic/paper sheet on every panel before rotating the display case back to it's correct orientation.

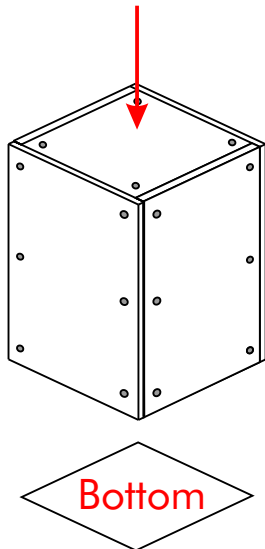

Place your figurine on the bottom panel before placing the case over the figurine, ensuring that the case sits snugly with the bottom panel.

Installation of the bottom 4 rivets is optional and not necessary.

Installing the bottom 4 rivets will make the case more sturdy but more difficult to access.

Continue to Pg. 11

# Admire your Display Case

Your display case is now complete.

If you haven't done so, we recommend our LED Base to light up your case along with a Customised laser engraved back panel.

Find out more at  
[ledisplaycase.com](http://ledisplaycase.com)